



**Report of Project No. VI20172020068**

**Tools and Methods for Video and Image  
Processing to Improve Effectivity of Rescue  
and Security Services Operations  
(VRASSEO)**

**Multisensoric board usable on  
drone**

December 2018

### **Abstract**

This report describes board which will be used on drone. This board could be used with large variety of sensors. So that it is possible to collect data from various different sensors and it has to be also possible to change the sensors so in different flight a different set of data could be acquired. Description and design and technical parameters are discussed in this report.

## Contents

VRASSEO MODULAR SENSOR BOARD SYSTEM .....	3
Description.....	3
Sensors and accesories overview .....	4
Motherboard basic functionality .....	4
Dimensions .....	4
Socket connector .....	5
MCU requirements .....	6
Power Supply features.....	6
Sockets....	7
MCU pinout.....	9
Sensors....	9

# VRASSEO MODULAR SENSOR BOARD SYSTEM

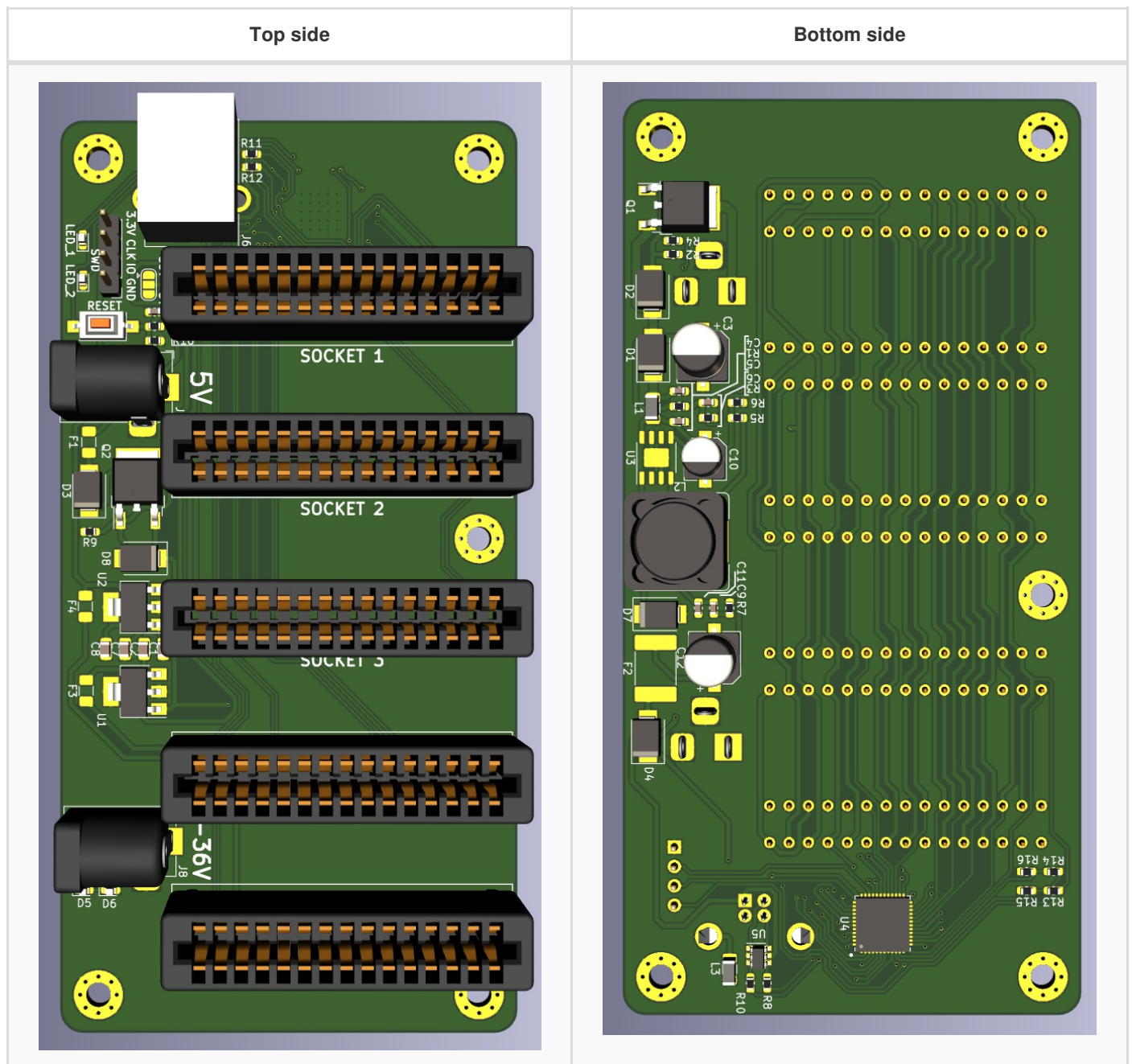

## Content

- [Description](#)
- [Socket connector](#)
- [Socket description](#)
- [MCU pinout](#)
- [Sensors](#)

## Description

This document is specification of sensoric board, which is made for UAV in project VRASSEO. Board is modular with different sensors described below. Sensors are placed on separated boards. These boards are inserted into slots on motherboard. Motherboard contains main procesor which operates with sensors, power management and slots for extension cards.

## **Sensors and accesories overview**

This is only summary of possible sensors, which can be added in future

- Barometr (diference of two barometrs can serve as altimetr) or one barometr can serve as relative altitude sensor
- Thermometr and humidity meter
- GPS module (supporting GPS, Galileo, Glonass) - Ublock MAX-M8 or Teseo-LIV3F
- Wi-fi module (probably some ESP)
- SD card reader (for saving measured data)
- IMU
- RGBW sensor (VEML6040)

## **Motherboard basic functionality**

- power management
- communication
- programming via SWD
- measuring voltages on power rails (3 channels)
- measuring internal MCU temperature
- status indication (powered, communicating, ...)

## **Dimensions**

Whole: 123x120x40 (mm)

## Socket connector

Type: Card edge connector, dual row, no flanges Pin count: 30 positions Link: [Mouser](#) Width: 44.7 mm Card edge width: 40.5 mm Board thickness: 1.3716 - 1.778 mm Pitch: 2.54 mm

### Model

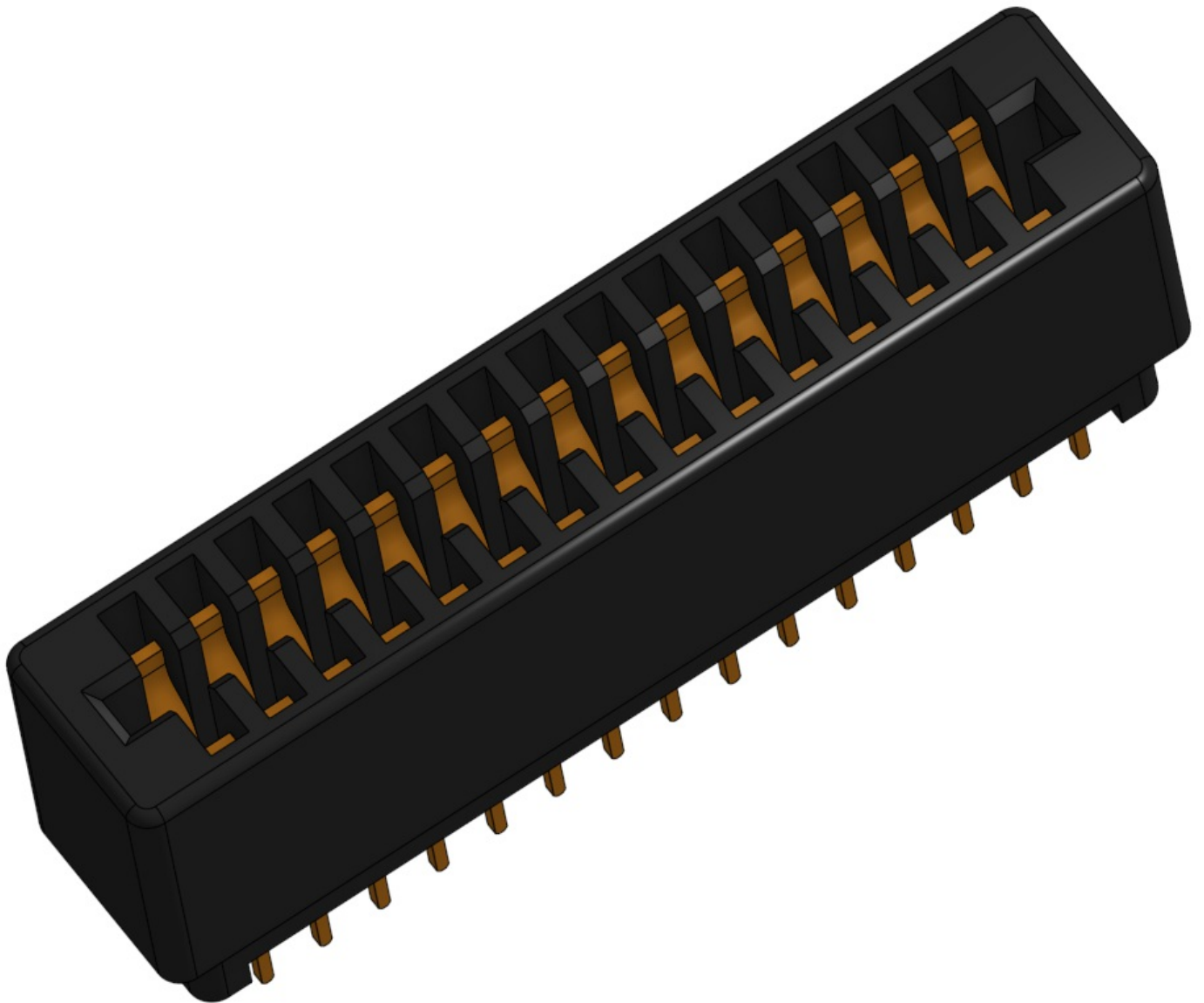

Count	Pins	Periferal	Description
1x	2	UART	Several UARTs are split between connectors
1x	3	SPI	Throught all ports, as CS can be used PP or SGP Pins
1x	2	I2C	Throught all ports
1x	2	CAN	Throught all ports
5x	1	GPIO	Pins for any usage shared throught all slots
2x	1	GPIO	Pins for any usage, exclusive one for one slot (IRQ and ADC)
1x	2	Power	1.8 V
1x	2	Power	3.3 V
1x	2	Power	5.0 V
4x	1	GND	Ground

Total required pins: 25 This is only estimation of pins usage, more detailed summary of socket pinout is in [Chapter Sockets](#)

## MCU requirements

- STM32 L4 series LowPower 80MHz MCU
- STM32L452CE
- 16 pins for socket peripherals (3x UART, 2x SPI, 1xI2C, 1xCAN)
- 12 pins as GPIO for slots (1x5-SGP, 7xPP)
- 3 pins for measuring voltages: Input, 5 V, 3.3 V (VMx)
  - 1.8 V voltage can be measured by Vrefint channel because MCU is powered by 1.8 V
- 4 pins for board communication, debug and programming (JTMS, USB-VCP)
- 2 pins for status LEDs (STATx)
- crystal-less High-speed USB 2.0 (USB\_Dx)
- total of 37 GPIOs -> QFPN48 package

## Power Supply features

- Reverse polarity protection (P-ch MOSFET) with LED signalization
- Main voltage measuring (voltage divider to ADC)
  - If Input power is not present ADC channel can be use for
- Ferrite bead for suppresing EMI noise
- Buck regulator (step-down converter) 5 V 2 A, Output 5.5 V
  - Buck converter: L5973D, up to 2.5A, input 3-36V
- Supply from USB, with precedence of main supply 5V (ORing)
  - Power draw limited by PTC fuses to USB2.0 limit (100 mA)

- This fuse also protect host device against shorts
- ORing diode lower USB voltage to 4.74V
- ORing is lowering 5.5 V to voltage around 5.1 V
- Low-ripple LDO regulators from 5 V to 3.3 V and 1.8 V
  - Regulators: MCP1826S, current capability 1A, Dropout 200-250mV @ 1A
- Sockets are current limited (limit is shared through all sockets)
  - 5 V -> 1 A, 3.3 V -> 700 mA, 1.8 V -> 700 mA
  - Limitation is realized via PTC fuses

## Sockets

On board there are two types of sockets. These type are differ in number of peripherals, available GPIOs. In every group is SPI shared through this group. Both types shares group of 5 GPIOs (SGP). Every socket have own private GPIO pin (PP). This pin can be use as ADC input or IRQ generator. Second type (T2) of socket have another private pin per socket.

Type 1 - Available USARTs Type 2 - More private GPIOs (+1 for every socket), No USARTs, DAC channels

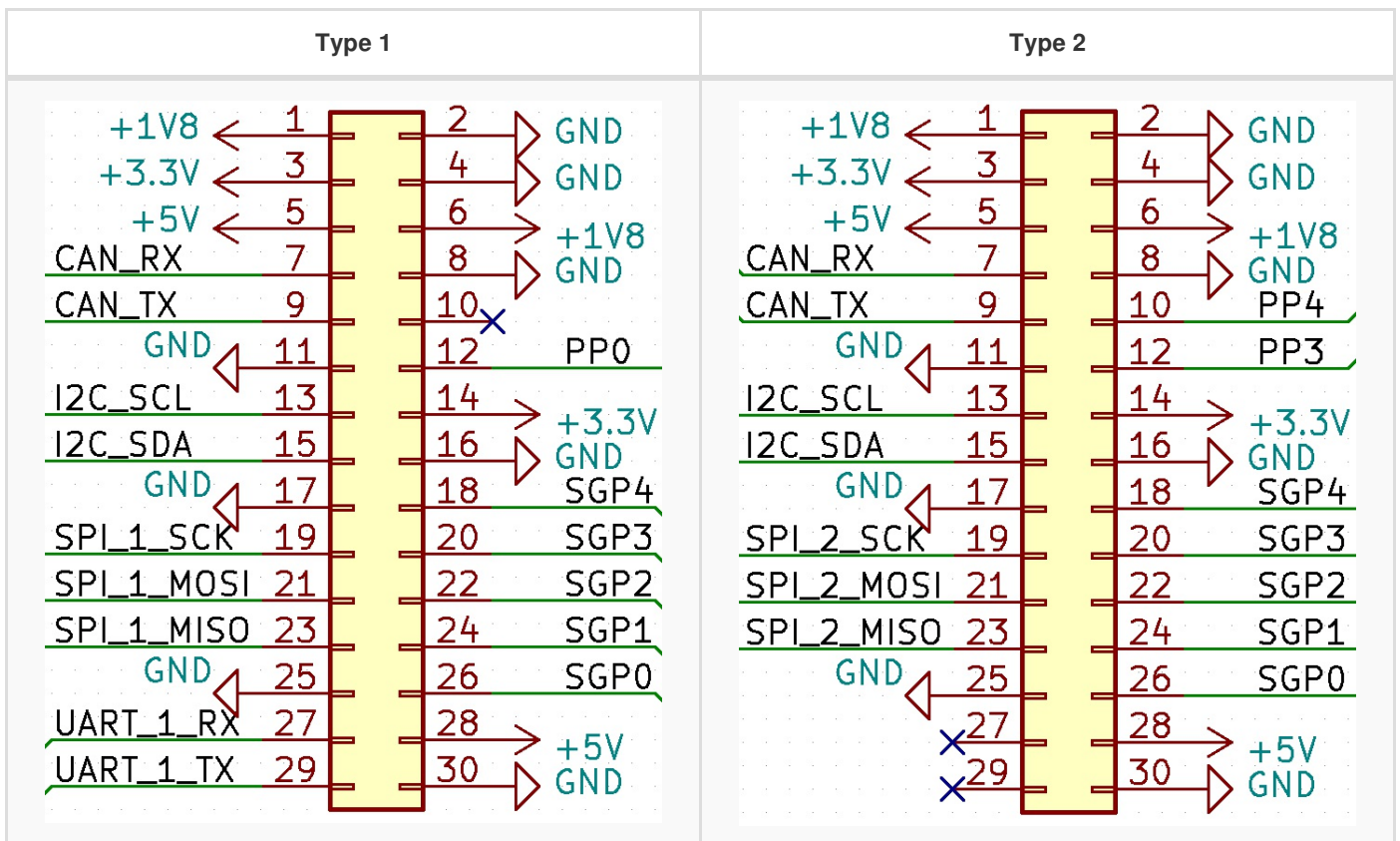



S1 - T1	S2 - T1	S3 - T1	S4 - T2	S5 - T2
UART1	UART2	UART3	---	---
SPI1	SPI1	SPI1	SPI2	SPI2
I2C1	I2C1	I2C1	I2C1	I2C1
CAN	CAN	CAN	CAN	CAN
SGP	SGP	SGP	SGP	SGP
PP0	PP1	PP2	PP3, PP4	PP5, PP6

### Shared pin description (SGP)

Desriptor	Port&Number	I/O	IRQ	ADC_IN	DAC_OUT
SGP0	PA4	YES	YES (13)	YES (9)	YES (1)
SGP1	PB0	YES	YES (0)	YES (15)	NO
SGP2	PB1	YES	YES (1)	YES (16)	NO
SGP3	PB2	YES	YES (2)	NO	NO
SGP4	PB14	YES	YES (14)	NO	NO

### Private pin description (PP)

Desriptor	Port&Number	I/O	IRQ	ADC_IN	DAC_OUT
PP0	PB8	YES	YES (8)	NO	NO
PP1	PA15	YES	YES (15)	NO	NO
PP2	PB9	YES	YES (9)	NO	NO
PP3	PH0	YES	YES (0)	NO	NO
PP4	PH1	YES	YES (1)	NO	NO
PP5	PC13	YES	YES (13)	NO	NO
PP6	PC14	YES	YES (14)	NO	NO

- all PP are IRQ capable on different vectors
- numbers in brackets are describing channel/vector of ADC,DAC/IRQ

# MCU pinout

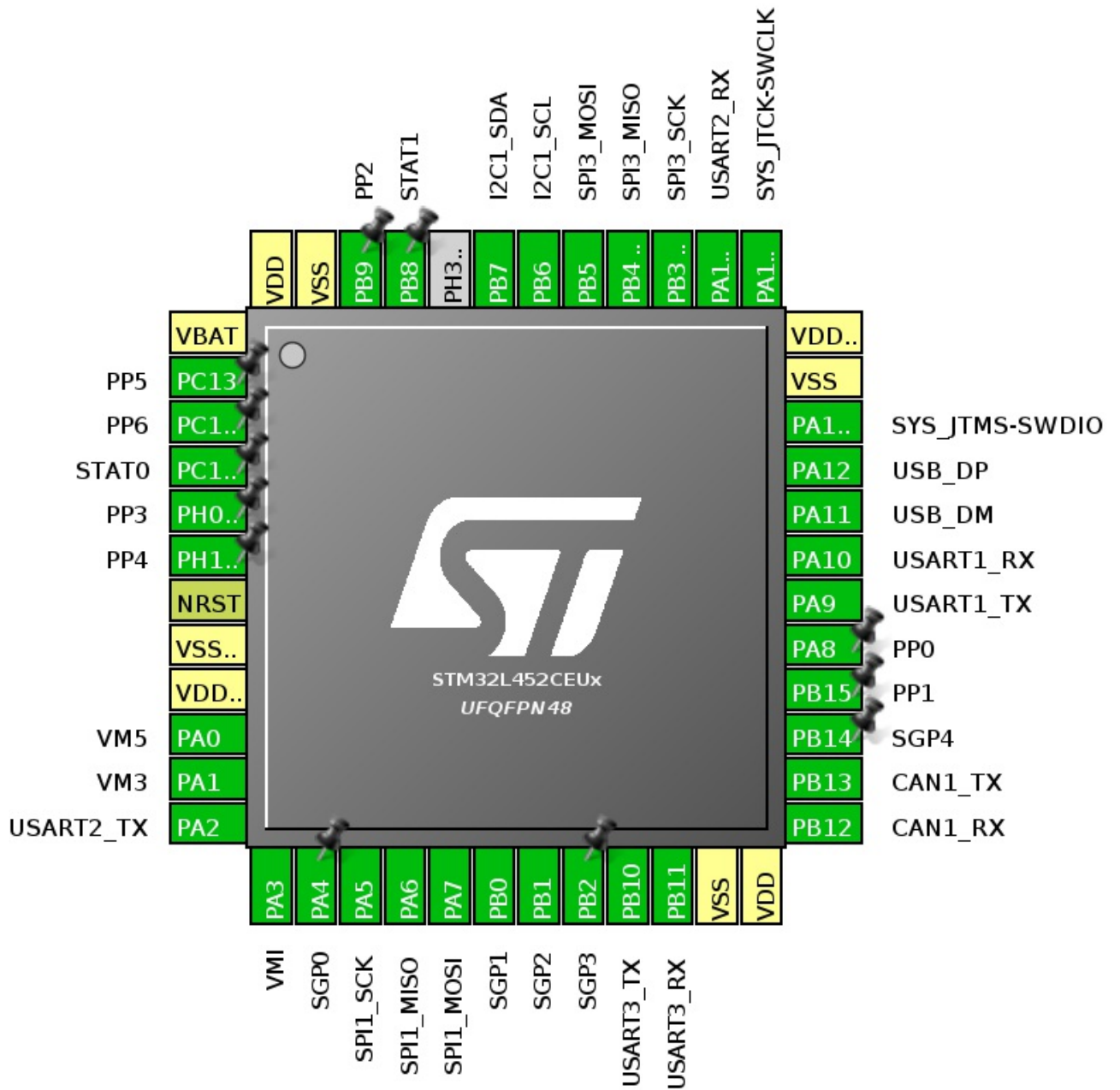

## Sensors

### Board 1

Can be inserted into slots: 1,2,3,4,5 Recommended slots: 4,5 Default slot: 4 All sensors are on I2C bus with 1.8 V and 3.3 V voltage supply

- BME208 -> temperature, pressure, humidity - [Mouser](#)
- VEML6040 -> color sensor RGBW - [Mouser](#)
- SI1145 -> IR and ambient light sensor, UV index measurement - [Mouser](#) Note: SI1145 is nearly imposible to solder without IR soldering station, for now is this sensor left not populated

### BME208

- LGA package - 2.5 x 2.5 x 0.93 mm
- I2C with freq. up to 3.4 Mhz
- VCC is 1.8 V

- Current consumption is around 8.2  $\mu\text{A}$  in 1 Hz measure mode
- Sleep current is 0.1  $\mu\text{A}$
- Operational temperature is from  $-40^{\circ}\text{C}$  to  $+85^{\circ}\text{C}$
- Accuracy of sensors:
  - 3% of relative humidity
  - typical  $\pm 1.0$  hPa
  - $\pm 0.5^{\circ}\text{C}$  at  $25^{\circ}\text{C}$  ( $1^{\circ}\text{C}$  at  $-15^{\circ}\text{C}$  or  $65^{\circ}\text{C}$ )
- I2C address: 111011x
  - first bit is selectable via input pin of sensor
- Three operation modes:
  - Sleep mode: no operation, all registers accessible, lowest power, selected after startup
  - Forced mode: perform one measurement, store results and return to sleep mode
  - Normal mode: perpetual cycling of measurements and inactive periods

**Sensor state transition diagram:**

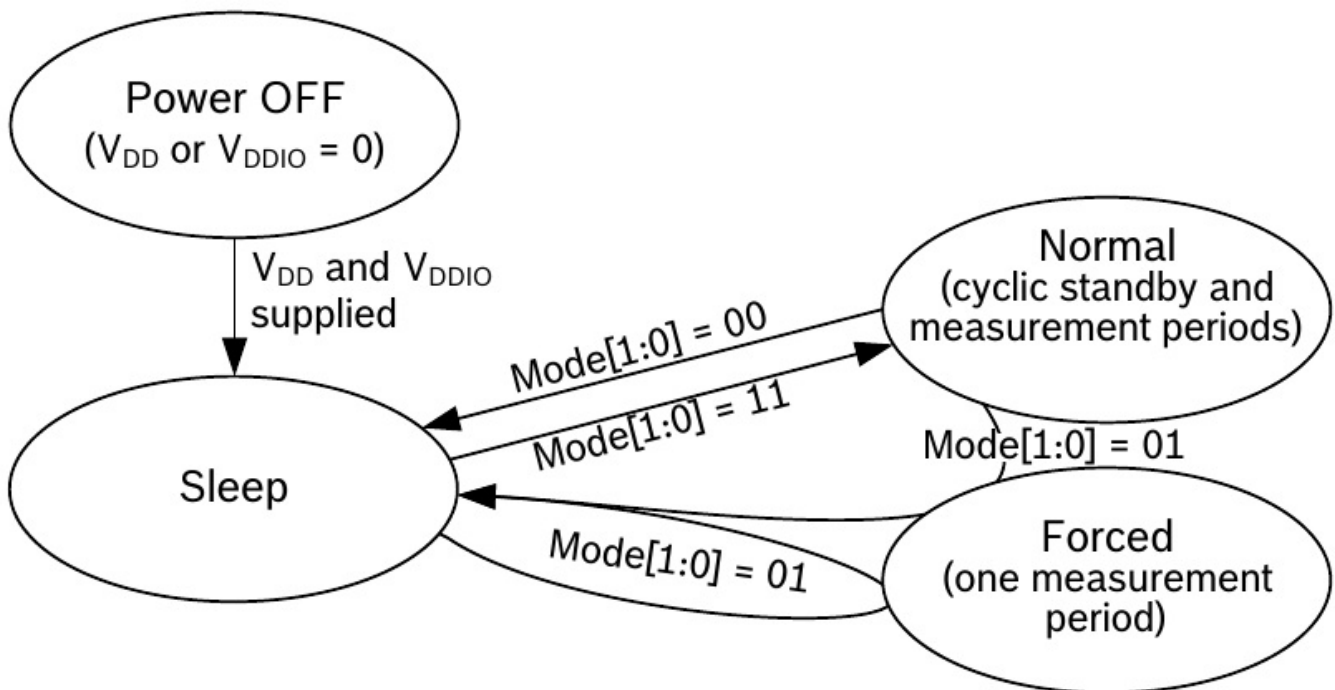

**VEML6040**

- OPLGA package - 2.0 x 1.25 x 1.0 mm
- VCC is 3.3 V
- I2C interface (SMBus compatible) (max 400kHz)
- 16-bit resolution for every color channel
- 16-bit registers
- I2C address: 0010000